



Performance Analysis of MIMO-OFDM System Based on SVD Scheme under Multi Path Selective Fading Channel

Hadj Ali Bakir A¹, Fethi Tarik Bendimerad B², and Fatima Debbat C², *

¹ University of Chlef, Algeria, electronic Department, Faculty of Technology A

² University of Tlemcen, Algeria, Departement of telecommunications, Faculty of Technology B

³ University of Mascara, Algeria, Department of Computer Science, Faculty of Technology C

(Received 03 Novembre 2018)

*Corresponding author: h.bakir@univ-chlef.dz

DOI: 10.5875/ausmt.v9i3.2049

Abstract: We consider in this paper a MIMO-OFDM wireless communication system based on pre-coding and SVD techniques, which the system has the feedback of CSI to the transmitted side. The multi path channel, delay spread, Rayleigh fading and channel noise are assumed in the simulation of the proposed system. The zero forcing method is applied for detection the data received. The purpose of this study proposed is to evaluate the BER performance and see it with different case about parameters. While The contribution of the MIMO-OFDM proposed system is appeared from the BER performance presented in the section result which the system have shown good improvement of BER in typical channel modeled by Rayleigh multi path channel while the improvement is kept particularly in the complex condition of the channel while the propagation considered by more paths until ten paths are used. And also the BER resulted show that the system guard important performance for high data rate either when the more carriers are used such as 128 and 256 and when more antenna (4×4) are simulated. The robustness of that system studied comes from using SVD scheme into the process of channel, from the pre-coding technique applied over the data transmitted and the properties of OFDM multi carriers that having such as guard interval, parallel transmission, and FFT technique.

Keywords: MIMO; MIMO-OFDM; OFDM; Selective fading; SVD

Introduction

The principal goals of modern wireless communication systems are to achieve high data rate, overcoming the limitation of bandwidth, give more reliability, and dealing well in complex wireless environment.

OFDM [1] is one of the transmission techniques that provides parallel data transmission over parallel orthogonal frequencies which ensure speed transmission and effectively using of the available bandwidth then high efficiency is obtained. It has other properties such as an adding of guard interval in OFDM symbols for reduce the interferences caused by the multi path propagation. Therefore, characteristics of OFDM system

have allowed it to perform with effective manner in multi path selective fading channels.

MIMO is also another important communication system, it studied with spatial multiplexing to increase the capacity of wireless channel since the parallel data streams are multiplexed in the same channel and used the same frequency without of any extension of bandwidth or power [2]. Here $M \times N$ channels will transmit different data in the same time.

The MIMO is combined with OFDM in many several studies [3-5] for the enhancement furthermore the performance of wireless communication.

There are several linear algebra decompositions that are applied in the field of processing signals. Such as singular value decomposition (SVD) [6-8], geometrical mean decomposition (GMD) [7], equal diagonal

decomposition (EQD) [9], and uniform channel decomposition (UCD) [10]. But the most popular decomposition method is the SVD decomposition. It has been proposed for the MIMO – OFDM system in many researches [11-13] to improve the performance and capacity of the system which the transmitter has knowledge of CSI and when the pre-coding is another technique applied over the data before that will be transmitted into the channel.

Furthermore, pre-coding and SVD techniques transform the MIMO-OFDM matrix channel into a set of parallel sub-channels, since the eigenvalues of diagonal matrix are the gains of these parallel sub-channels. In that way, the capacity of communication system is increased, the performance is improved and the complexity of detection the signals in the receiver side is decreased [12-13]. In this issue, we contribute from this study by analysis the system MIMO-OFDM considered SVD scheme under wireless environment while we provide a BER comparison when the increased in the capacity of MIMO-OFDM system either on by using more sub-carriers for OFDM or particularly more transmit or receive antennas are used for MIMO, the BER performance loosed is greatly low compared to a capacity of channel gained. And the system proposed keep their robustness against of spread fading channel when we compared different conditions of multi path channel in the simulation. This paper is organized as following the SVD decomposition scheme is discussed firstly in the section II. Then, the principal of associated MIMO with SVD is done in the section III. After that, in section IV we discussed the proposed associated

MIMO-OFDM system that concatenated with both SVD and pre-coding techniques. Finally, the simulation results are given in the section V and we finished the paper by a conclusion.

II. SVD TECHNIQUE APPLIED

The SVD scheme is a linear algebra function applied over a matrix of channel, when the signal is passed through it. In order to create independent parallel sub-channels of MIMO system for increase the array antenna gain and the performance is increased also [14-15]. The SVD function is formulate as following:

$$H = U\Sigma V^H \quad (1)$$

Where H: is the original given channel MIMO matrix that will transfer into singular value decomposition as shown in the equ.1

U and V: are both unitary matrix, which ($UU^H = 1$ and $VV^H = 1$) Or U is the left column SV having $N_r \times N_r$ size, and V is the right column SV having $N_t \times N_t$ size.

Σ Is the diagonal matrix which has $N_r \times N_t$ size. The diagonal elements are singular values defined by $\sigma_1, \sigma_2, \dots, \sigma_m$ which $\sigma_1 \geq \sigma_2 \geq \dots \geq \sigma_m$.

In that way, the m-th sub channels of MIMO system has the gain being σ_i , and the data streams transmitted from N_t antenna are independent from these independent parallel sub-channels and the wireless channels related i-th transmit antenna and j-th receive antenna are free of interference of each other [13].

III. MIMO SYSTEM

A multiple antenna communication system is based on three types of signal processing that consisting of beamforming technique [16] to adapt the signal in the best direction which there are a minimum obstacles, space-time diversity [17-18] has been proposed for improvements the reliability of the wireless communication and then the effect of the fading phenomenon is decreased, and spatial multiplexing suggested in [2] has shown the increased of the data rates in wireless communication links.

As known, a key advantage of MIMO is to increase the capacity of communication system in the SISO link that is defined from a Shannon capacity which this capacity in that system is increased just by the power increasing and extension on the bandwidth used, as shown in the formulate:

Bakir Hadj Ali received diploma of engineer in telecommunication in 2009 from Department of Electrical and Electronic Engineering at the University of Tlemcen, Algeria and the Magister degree in Telecommunication Systems from the same university in 2012 and Ph.D. Degree in telecommunication, in 2017 from the same University also. He is assistant at university of chlef since 2015. His current research in Telecommunication field includes the areas of wireless communications and digital communications such as MIMO, OFDM, and STBC coding.
E-Mail: h.bakir@univ-chlef.dz

Bendimerad Fethi Tarik received the engineering degree in 1983 from the Science and Technology University in Oran, Algeria and the Doctorate Degree from Nice Sophia Antipolis University, France, in 1989. He is professor at university of Tlemcen since 1990. He was the Director of the Telecommunications Laboratory of Tlemcen for more than 10 years. He is the author and co-author for more than 130 international indexed journal papers. He was the supervisor for many research projects. He is currently the leader of the digital communication section at LTT laboratory. His main areas of research are wireless systems, Digital communications and MIMO systems.
E-Mail: febendimerad@gmail.com

Debbat Fatima received gis bachlor degree in 1996 from Science and technology University of Oran USTO, and a master Degree in Space Technologies, in 2002 from the Space Techniques Center (CTS) Algeria and Ph.D. Degree in electronics, in 2007 from University of Tlemcen, Algeria. She is Currently Assistant at the department of computer Science in Mascara University, Algeria. Her current research interest covers Artificial Intelligence Applications, Optimization and Wireless Networks.
E-Mail: debbat_fati@yahoo.fr



$$C = W \log_2(1 + SNR) \quad (2)$$

But this capacity theory has been changed by the integration of multiple antennas at the transmitter and the receiver sides.

For the MIMO system known by asymmetrical antennas when the transmit or receive diversity is used. In that system, the capacity grows logarithmically with the number of antennas as written [19]:

$$C = W \log_2(1 + m * (SNR)) \quad (3)$$

A MIMO system studied across this paper that is called a spatial multiplexing, or a linear capacity gains are done in relation of minimum between the numbers of transmit antenna and receive antenna $m = \min(N_t, N_r)$. Hence, the improvements in the capacity are shown in the following formulate of the capacity [19]:

$$C = m * W \log_2(1 + SNR) \quad (4)$$

Now, let's a $S^{N_t \times 1} [n]$ the vector symbol that will transmit by MIMO system over n during symbols using spatial multiplexing, or s_1 and s_2 are two symbols will transmitted by 1-st and 2-nd antennas respectively, and these symbols passed through h_{ij} paths related between a transmit antenna and receive antenna. We used a selective fading channel environment, followed a Rayleigh distribution with multi path on each sub channels as written in the following channel matrix:

$$H = \begin{bmatrix} h_{11}^l & h_{12}^l \\ h_{21}^l & h_{22}^l \end{bmatrix} \quad (5)$$

As shown in the above matrix, each sub-channels of MIMO system considered is presented by multi path, while the l denoted the number of paths defined each by a gain value and corresponding a delay spread.

The received sequence symbols $y_1[n]$ and $y_2[n]$ at 1-st and 2-nd receive antennas respectively during n -th symbol interval is given in the discrete time as:

$$\begin{bmatrix} y_{1,n} \\ y_{2,n} \end{bmatrix} = H \begin{bmatrix} s_{1,n} \\ s_{2,n} \end{bmatrix} + \begin{bmatrix} w_{1,n} \\ w_{2,n} \end{bmatrix} \quad (6)$$

Where: H is the impulse response of wireless channel given in equation (5).

And we can write the previous equation of signal received as:

$$Y = HS + W \quad (7)$$

Since the MIMO system proposed based on the SVD scheme, then the signal is treated as shown on the following figure [13]:

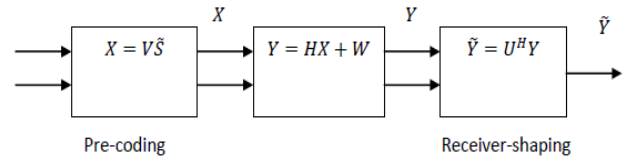

Figure 1. Principle of SVD scheme for MIMO system.

We can see in the above illustration, the signal processing of MIMO-SVD technique require pre-coding process at the transmitter side and receive shaping at the receiver side.

For that case, the previous received signal will be multiplying with U^H and written as [14]:

$$\tilde{y} = U^H(HS + W) \quad (8)$$

And we substitute the value of H obtained by SVD decomposition into above, we get

$$\tilde{y} = U^H(U\Sigma V^H S + W) \quad (9)$$

After substitute also X by $S = V\tilde{S}$ into above, we obtain also:

$$\begin{aligned} \tilde{y} &= U^H(U\Sigma V^H S + W) \\ &= U^H(U\Sigma V^H V\tilde{S} + W) \\ &= U^H U \Sigma V^H V\tilde{S} + U^H W \\ &= \Sigma \tilde{S} + \tilde{W} \end{aligned} \quad (10)$$

As seen in a resulted signal, it depends of the input pre-coded signal \tilde{S} that multiplied by the diagonal matrix Σ . After [20] the distribution of noise doesn't change if that noise W is multiplied by the unitary matrix Σ .

IV. MIMO-OFDM system based on SVD

We consider a MIMO-OFDM wireless communication system in selective fading environment. In first, we generated a binary data passed then into a modulation process that given a complex vector defined as s_1, s_2, \dots, s_i where S_i denotes the i -th symbol done by QAM modulation. After that, the pre-coding operation is applied in order to pre-codes the modulated symbol and generates a vector symbol $X = (x_1, x_2, \dots, x_i)$ (see figure 2). To be mapped after onto N_t transmit antenna that having each an OFDM module.

Here, V is the unitary matrix given by a singular value decomposition of channel matrix.

Furthermore, with the SVD scheme the transmitter of MIMO-OFDM studied has a full knowledge of H [20- 21]. According to the criterion of the SVD the MIMO channel matrix is decomposed as $(H = U\Sigma V^\dagger)$ and \dagger denotes the Hermitian transpose.

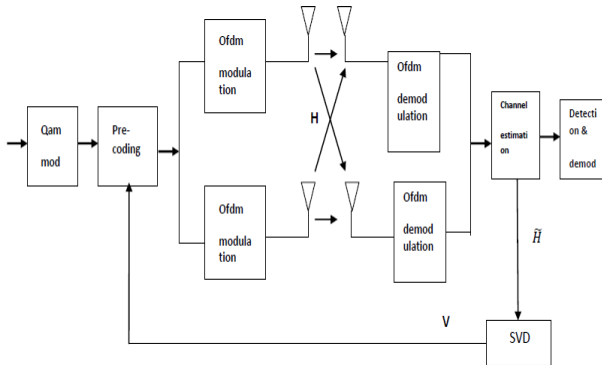

Figure 2. Bloc diagram of the MIMO-OFDM system based on the SVD and pre-coding techniques.

The output vector of pre-coding process is:

$$X = V * S \tag{11}$$

A transmitter has pre-process the transmitted symbols with a unitary a prefilter V , this process is called pre-coding. And the receiver will post process with a unitary filter U^\dagger (shaping receiver, see figure 1). Let $\{X_{i,k}^{N_t \times 1}\}_{k=0}^{K-1}$ be the input symbols to N-point IFFT for i-th transmit antenna, $X_{i,k}$ denotes also the input symbol on the frequency domain. The output symbol of IFFT function can be written as:

$$X_{i,n}^{N_t} = \frac{1}{\sqrt{N}} \sum_{k=0}^{K-1} X_{i,k}^{N_t} e^{j\frac{2\pi nk}{N}} \quad 0 \leq n \leq N - 1 \tag{12}$$

The guard interval is added in front of each IFFT sequence symbols generated. The main function of GI is to protect the propagation signal from interference that come by the delay spread of different paths considered in our system. Although, the signal presented at each transmit antenna will propagate through a multipath Rayleigh fading channel, as described in the following matrix:

$$H = \begin{bmatrix} h_{11}^{l_i, d_i}[k] & h_{12}^{l_i, d_i}[k] \\ h_{21}^{l_i, d_i}[k] & h_{22}^{l_i, d_i}[k] \end{bmatrix} \tag{13}$$

As seen in the above matrix, each sub channel of (2×2) MIMO system is defined by:

l_i : denotes the gains of impulse response for different paths.

d_i : denotes the delay spread corresponding the i-th path.

k : denotes the number of sub-carriers for OFDM system. Such that, the channel matrix is decomposed into SVD, then the diagonal singular values of Σ matrix in OFDM multi-carrier modulation being $\sigma = [\sigma_1(K), \sigma_2(K)]$ which K represents the number of sub-carriers, which the data streams done from two transmit antennas are multiplexed into the same channel where SVD make it independently through the spatial sub-channels with gains corresponding to the entries of the matrix. At the receiver, these data streams arrive orthogonally without interference between streams [22].

The received signal of that MIMO-OFDM system is given by:

$$y_{j,n}(k) = \sum_{i=1}^{N_t} \sum_{j=1}^{N_r} \sum_{k=1}^K h_{ij}(k)X_{i,n}(k) + w_{j,n}(k) \tag{14}$$

The signals received at each receive antenna from k-th sub-carrier are:

$$y_{1,n}(k) = \sum_{i=1}^{N_t} \sum_{k=1}^K h_{i1}(k)X_{i,n}(k) + w_{1,n}(k) \tag{15}$$

$$y_{2,n}(k) = \sum_{i=1}^{N_t} \sum_{k=1}^K h_{i2}(k)X_{i,n}(k) + w_{2,n}(k) \tag{16}$$

$y_{1,n}$ and $y_{2,n}$ are both the received signals at 1-st and 2-nd receive antennas respectively, and in during n-th interval symbol that presented by K sub-carriers.

$w_{1,n}$ and $w_{2,n}$ are both the additive white Gaussian noise at 1-st and 2-nd receive antennas respectively, and in during n-th interval symbol that presented by K sub-carriers.

The demodulated signal is done after the applied of FFT function over the signal $y_{j,n}(k)$:

$$Y_{j,n}(k) = FFT(y_{j,n}[k]) \tag{17}$$

$$Y_{j,n}(k) = \sum_{i=1}^{N_t} \sum_{n=0}^{N-1} \sum_{k=0}^K h_{ij}(k)y_{j,n}(k)e^{-\frac{j2\pi kn}{N}} + w_{j,n}(k) \tag{18}$$

The FFT operation is followed by the suppression of guard interval added on the OFDM sequence symbols at the transmitter side. After that, we need also to estimate the desired input signal from the serial signal

obtained in the inverse operations of OFDM modulation. The serial signal resulted is multiplied by U^H as demonstrated for MIMO signal in the last section 3.

Then, the last operation before QAM demodulation in the receiver side is the linear ZF detection which has decreased the effect of the fading channel when the signal is multiplied also to the function of ZF that given by:

$$W = H^\dagger = (H^*H)^{-1}H^* \tag{19}$$

V. Simulation results

In this section, and after we have taken the benefits of SVD scheme into wireless channel from render it parallel independent [14], and the efficient of the ZF receiver method on the reception side in MIMO-OFDM [23-24]. All these techniques combined and applied them from the spatial MIMO-OFDM transmission system adapted for high data rate binary. So for that, we provide the analysis of the simulation results under selective Rayleigh fading environment. where the system done is constructed as following: binary data is generated in the first, QAM modulation and pre-coding processes are applied over the sequence generated. Afterwards, the vector symbol done is divided into N_t vectors here the MIMO spatial multiplexing are made, while each N_t chain constitute of OFDM modulation. Then, a selective multi path Rayleigh (each path corresponds a gain done in dB and their corresponding a delay spread) is considered that decomposed with the SVD criterion for the target discussed in the above sections.

In the receiver; the inverse operations are made and ZF linear detection is applied before the bit error rate is measured in different SNR values.

The purpose of this study and across this section. Firstly, to evaluate a BER performance of the MIMO-OFDM based on SVD for different parameters of OFDM transmission such as in different number of sub-carriers and in different guard interval lengths (see figure 3 and figure 4 respectively).

Secondly, we evaluated the BER of MIMO-OFDM system after we changed the number of paths simulated (see figure 5), and we used two constellation size of QAM modulation for the system simulated in figure 6

Thirdly, two configurations are compared in the figure 7 and figure 8 successively. When we compared the MIMO-OFDM system with the SISO-OFDM system in figure 7. And two architectures of MIMO-OFDM are also compared; they are different on the antenna number used (see figure 8).

We present the parameters used in the simulation of MIMO-OFDM system in the following table:

Table 1. Simulation parameters of the system proposed.

Parameters used	Specifications
Binary sequence	$100 \times M$
QAM modulation (M-QAM)	4-QAM, 8-QAM
Number of transmit antennas (Mt)	1,2,4
Number of receive antennas (Mr)	1,2,4
Number of sub-carriers (Nsc)	64, 128, 256
Guard interval length (GI)	12, 16
Channel type	Multi path Rayleigh fading
Number of paths (L)	1, 3, 10
Detection method	Zero forcing

Figure 3 shows a BER performance of MIMO-OFDM for different sub-carriers when we used 8-QAM modulation, the samples reserved for guard interval added in OFDM symbol is fixed into 16, the number of paths used is 3paths. And we changed the sub-carriers number of OFDM system for see their effect in BER of MIMO-OFDM communication system.

Figure 4 shows the effect of guard interval length on the performance of the MIMO-OFDM system. When we simulated two different GI lengths.

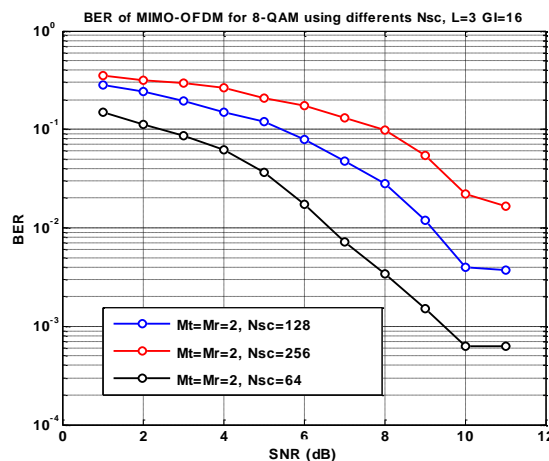

Figure 3. BER performance of (2 × 2) MIMO with different sub-carriers (8 – QAM, L = 3, and GI = 16).

We can see from figure 3 the BER of MIMO-OFDM system is increased when the sub-carriers number simulated is increased also. This difference in result obtained came from the increase in QAM symbols supported by a system if we increase the Nsc simulated, such as in each chain (two chains are available by using Nt=2). On each chain, with using a Nsc =256 the system will transmit 256 symbols simultaneously and with using a Nsc = 128 the system will transmit 128 symbols per

simultaneously and finally 64 symbols will transmitted by using $N_{sc} = 64$. Finally we can say for that, the higher numbers of sub-carriers means higher data rates and also higher spectral efficiency have given [3].

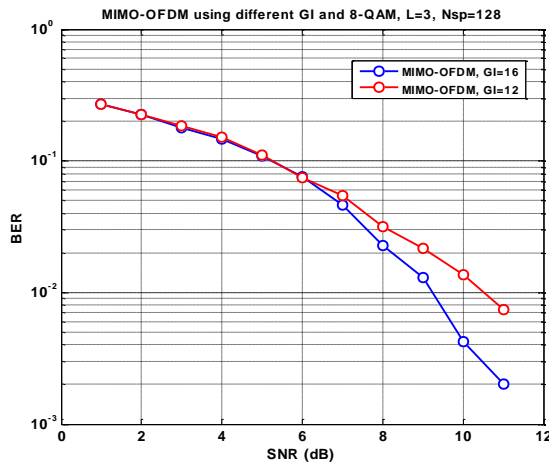

Figure 4. BER performance of (2×2) MIMO with different length of guard interval ($8 - QAM$, $L = 3$, and $N_{sc} = 128$).

And in above curves simulated in figure 4, we varied the samples of guard interval in OFDM transmission for the same condition as figure 1. Where $GI = 12$ and $GI = 16$ are used. It can be seen, the BER performance of MIMO-OFDM decreased when we decreased the simulated samples added in front of each OFDM symbol. Particularly in higher values of SNR, as seen from $SNR = 6\text{ dB}$ the gap in BER resulted began to increase until $SNR = 11\text{ dB}$. Consequently, there is more a probability that the MIMO-OFDM system having more interference if the length of guard interval is small compared with the maximum delay made by the last path of multi path MIMO channel. Which it result interference between two successive symbols OFDM received [1, 25].

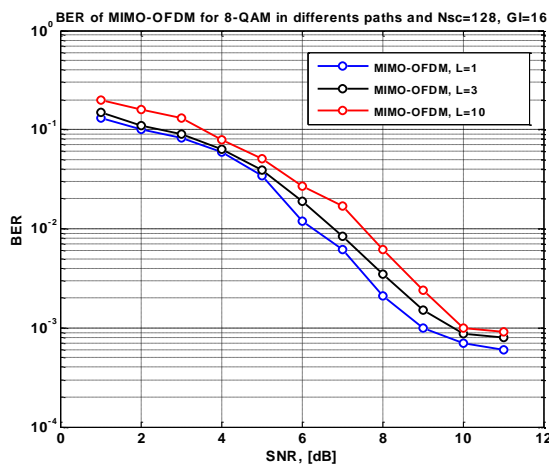

Figure 5. BER performance of (2×2) MIMO with different paths of wireless channel ($8 - QAM$, $GI = 16$, and $N_{sc} = 128$).

Figure 5 shows the BER performance of MIMO-OFDM system simulated using different paths, ($L = 1$ one path, $L = 3$ paths, and $L = 10$ paths respectively). As seen there is almost no difference in the BER measured for three cases chosen of channel condition. Here it appeared the robustness done by SVD decomposition channel which these paths of each sub-channels of MIMO matrix channel considered independently in space and no interference affected from each other [11-13]. Until $L = 10$ paths (or probability of more obstacles available in propagation environment) the performance remains constant and approaches to $L = 1$ path (direct path).

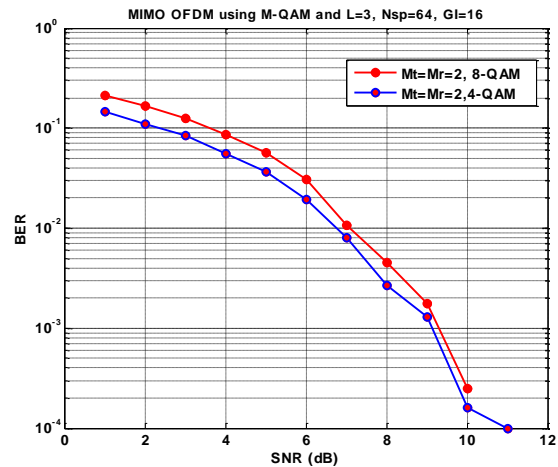

Figure 6. BER performance of (2×2) MIMO with two constellation size of QAM modulation ($N_{sc} = 64$, $GI = 16$, and $L = 3$ paths).

We compared in figure 6 the BER performance of MIMO-OFDM in two constellations size for QAM modulation (4-QAM and 8-QAM). Here we can see a little difference in BER provided which the 4-QAM is considered best in performance resulted as compared it with the performance of 8-QAM. Because the sequence simulated by 8-QAM (800 bit) is two times as compared to sequence simulated by 4-QAM (400 bit) as shown in the table of simulation parameters or that means more data rates simulated by using 8-QAM.

Hence, with 8-QAM the MIMO-OFDM system will transmit more data when each symbol generated from QAM modulation supported by a one carrier of OFDM. As example, if 4-QAM is used (2 symbols supported by each carrier) and if 8-QAM is used (3 symbols supported by each carrier).

Thus, the sequence simulated either on 4-QAM or 8-QAM was not chosen randomly but relatively to theory of digital modulation that say higher constellation size of modulation means higher data rates transmitted over any communication system [26].

From a comparison of BER performance shown in

two above figures (figure 7 and figure 8), we can see that added one antenna from SISO architecture to (2×2) MIMO architecture (figure 7) and to pass from (2×2) MIMO to (4×4) MIMO architectures (figure 8). The BER curves shows that the performance losses are low compared to the capacity of data rate that has gained by (2×2) MIMO-OFDM and (4×4) MIMO-OFDM respectively.

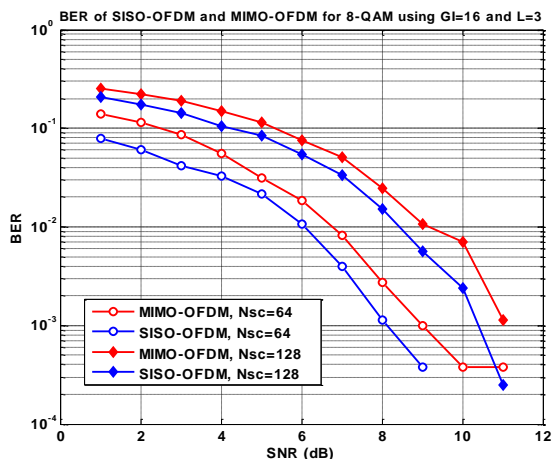

Figure 7. BER comparison between SISO-OFDM and MIMO-OFDM for 8-QAM and using $(N_{sc} = 64, GI = 16,$ and $L = 3$ paths).

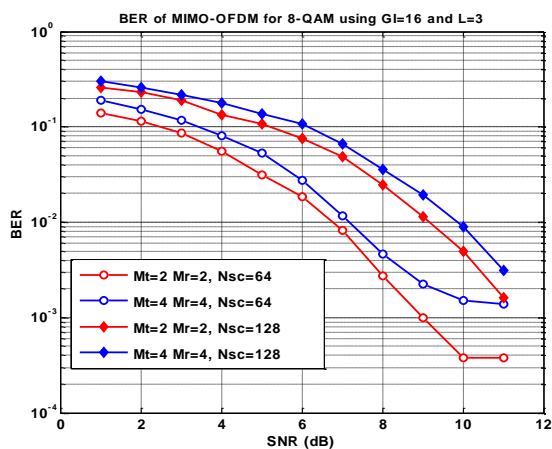

Figure 8. BER comparison between two configurations of MIMO-OFDM for 8-QAM and using $(N_{sc} = 64, GI = 16,$ and $L = 3$ paths).

So, if the system has two transmit antennas two receive antennas that are means has also two OFDM modules on each antenna of two sides of communication link. Where the data transmitted by using (2×2) MIMO architecture is two times that data transmitted by using (1×1) SISO. Same explanation is applied for two configurations of MIMO associated with OFDM (figure 8). As consequence, the communication system of MIMO-OFDM proposed keeps their robustness against selective multipath fading despite the speed in the data transmission ensured by using more antennas.

Conclusion

In this paper, the performance of 2×2 MIMO based on SVD scheme is evaluated for OFDM multi carrier modulation under Rayleigh multi path channel. The simulation results of the proposed system has presented low BER performance for high data rate most particularly with 64 carriers that used. And it has lost a certain gap in SNR of their performance with using 256 carriers. Other improvement achieved across the system provided is obtained when it has simulated under more paths when we considered 10 paths in the wireless channel which the system guard almost the same performance of 1 path and 3 paths using in the comparison. As we have seen from the last comparison of BER performance the passed from the SISO architecture to 2×2 MIMO architecture and then to 4×4 MIMO architecture respectively the system has kept also their performance with no considerable lost in SNR for 4×4 MIMO.

Finally, from this study presented we can say all the techniques combined in the proposed system of MIMO-OFDM such as pre-coding, SVD scheme, ZF has given the system proposed a good robustness against the selective fading channel and against noise considered in the simulation.

References

- [1] T. Hwang, C. Yang, S. Wu, G. Li, and G. Y. Li, "OFDM and Its Wireless Applications: A Survey," *IEEE Transactions on Vehicular Technology*, vol. 58, no. 4, pp. 1673-1694, 2009. doi: [10.1109/tvt.2008.2004555](https://doi.org/10.1109/tvt.2008.2004555)
- [2] J. Akhtar, and D. Gesbert, "Spatial multiplexing over correlated MIMO channels with a closed-form precoder," *IEEE transactions on Wireless Communications*, vol. 4, no. 5, pp. 2400-2409, 2005. doi: [10.1109/twc.2005.853915](https://doi.org/10.1109/twc.2005.853915)
- [3] J. Xuehua, and C. Peijiang, "Study and Implementation of MIMO OFDM System Based on Matlab," *IEEE Computer Society: International Conference on Information technology and Computer Science*, vol. 1, pp. 554-557, 2009. doi: [10.1109/itcs.2009.120](https://doi.org/10.1109/itcs.2009.120)
- [4] T. Chanpokapaiboon and P. Puttawanchai and P. Sukksompong, "Enhancing PAPR performance of MIMO-OFDM systems using SLM technique with centering phase sequence matrix," in proceeding of *The 8th Electrical Engineering/ Electronics Computer, telecommunications and Information Technology (ECTI), Thailand*, May 17-19, 2011, pp. 405-408. doi: [10.1109/ecticon.2011.5947860](https://doi.org/10.1109/ecticon.2011.5947860)
- [5] V. Rao, and T. Malavika, "Performance Analysis of

- MIMO-OFDM for 4G Wireless Systems under Rayleigh Fading Channel,” *International Journal of Multimedia and Ubiquitous Engineering*, vol. 8, 2013.
- [6] C. Studer, P. Bloesch, P. Friedli, A. Burg, “Matrix Decomposition Architecture for MIMO Systems: Design and Implementation Trade-offs,” in proceeding of *Conference Record Forty-First Asilomar Conf. Signals, Sys. Comput.*, Pacific Grove, CA, Nov. 4-7, 2007, pp. 1986-1990.
doi: [10.1109/acssc.2007.4487584](https://doi.org/10.1109/acssc.2007.4487584)
- [7] C.-Z. Zhan, Y.-L. Chen and A.-Y. Wu, “Iterative Superlinear-Convergence SVD Beamforming Algorithm and VLSI Architecture for MIMO-OFDM Systems,” *IEEE Transactions on Signal Processing*, vol. 60, no. 6, pp. 3264-3277, 2012.
doi: [10.1109/tsp.2012.2190405](https://doi.org/10.1109/tsp.2012.2190405)
- [8] R. Raja Kumar, P. Indumathi, “Linear precoding using Transmitter Site Channel Estimation for MIMO-OFDM Systems,” *International Journal of Applied Engineering Research*, vol. 2, no. 19, pp. 8609-8614, 2017.
- [9] J.-K. Zhang, A. Kavcic and K. M. Wong,, “Equal-diagonal QR decomposition and its application to precoder design for successive cancellation detection,” *IEEE Trans. Information Theory*, vol. 51, pp. 154-172, 2005.
doi: [10.1109/TIT.2004.839475](https://doi.org/10.1109/TIT.2004.839475)
- [10] Y. Jiang, J. Li and W.W. Hager, “Uniform channel decomposition for MIMO communications,” *IEEE Trans. Signal Process*, vol. 53, no.11, pp. 4283-4294, 2005.
doi: [10.1109/TSP.2005.857052](https://doi.org/10.1109/TSP.2005.857052).
- [11] Yen-Liang Chen, Cheng-Zhou Zhan, Ting-Jyun Jheng, and An-Yeu,” Reconfigurable Adaptive Singular Value Decomposition Engine Design for High Throughput MIMO-OFDM Systems,” *IEEE Transactions On Very Large Scale Integration (VLSI) Systems*, vol. 21, no. 4, 2013.
doi: [10.1109/tvlsi.2012.2195040](https://doi.org/10.1109/tvlsi.2012.2195040)
- [12] Mr. A. Dileep, M. Silvi Sheba, “SVD based performance improvement of multi path fading channels,” *Global Journal of advanced Engineering Technologies*, vol. 6, Issue 1, pp. 44-48, 2017.
- [13] Y.-T. Hwang, K.-T. Chen, and C.-K. Wu, “A High Throughput Unified SVD/QRD Precoder Design for MIMO OFDM Systems,” in proceeding of *IEEE International Conference on Digital Signal Processing (DSP)*, Singapore, July 21-24, 2015, pp. 1148-1151.
doi: [10.1109/icdsp.2015.7252059](https://doi.org/10.1109/icdsp.2015.7252059)
- [14] C. Langton, “Tutorial 27 Finding MIMO, Available: <http://www.complextoreal.com>, Oct 2011.
- [15] M. Narayana and G. Bhavana “Performance Analysis of MIMO System under Fading Channels (Rayleigh & Rician) Using SVD, PCA, & FSVD,” *Journal of Engineering Technology*, vol. 5, Issue 2, pp. 116-126, 2016.
- [16] M. H. Golbon-Haghighi, “Beamforming in Wireless Networks,” *In Tech Open*. pp. 163–199. 2016.
doi: [10.5772/66399](https://doi.org/10.5772/66399)
- [17] S. M. Alamouti, “A simple transmitter diversity scheme for wireless communications,” *IEEE J. Select. Areas Commun*, vol. 16, pp. 1451–1458, 1998.
doi: [10.1109/49.730453](https://doi.org/10.1109/49.730453)
- [18] V. Tarokh, H. Jafarkhani, and A. R. Calderbank, “Space-time block codes from orthogonal designs,” *IEEE Trans. Information. Theory*, vol. 45, pp. 1456–1467, 1999.
doi: [10.1109/18.771146](https://doi.org/10.1109/18.771146)
- [19] M. Noor-A-Rahim, Md. Saiful Islam, Md. Nashid Anjum, Md. Kamal Hosain, A. Kouzani “Performance Analysis of MIMO-OFDM System Using Singular Value Decomposition and Water Filling Algorithm,” *International journal of advanced computer science and applications*, vol. 2, no. 4, 2011.
doi: [10.14569/ijacsa.2011.020407](https://doi.org/10.14569/ijacsa.2011.020407)
- [20] A. Goldsmith, *Wireless communications*, Cambridge University Press, 2004.
- [21] E. Telatar, “Capacity of multi-antenna gaussian channels,” *Transactions on Emerging Telecommunications Technologies*, vol. 10, no. 6, pp.585-595, 1999.
doi: [10.1002/ett.4460100604](https://doi.org/10.1002/ett.4460100604)
- [22] E. S.Rajeswari, V. Prathibha, “hardware efficient singular value decomposition in mimo-ofdm system,” *international journal of electronics and communication engineering & technology*, vol. 5, no. 12, pp. 99-105, 2014.
- [23] M. Jangalwa, “Performance analysis of MIMO OFDM system with zero Forcing Receiver,” *International Journal of Multidisciplinary and Current Research*, 2013.
- [24] J.-H. Ro, J.-K. Kim, Y.-H. You and H.-K. Song, “Linear approximation Signal Detection Scheme in MIMO-OFDM Systems,” *Applied sciences*, vol. 8, no. 49, 2018.
doi: [10.3390/app8010049](https://doi.org/10.3390/app8010049)
- [25] S. C. Yong, K. Jaekwon, Y. Y. Won, and G. K. Chung, *MIMO-OFDM wireless communications with Matlab*. Singapore: John Wiley & Sons (Asia), 2010.
doi: [10.1002/9780470825631](https://doi.org/10.1002/9780470825631)
- [26] B. Manoj, and K. Suresh, “Digital modulation schemes employed in wireless communication: A literature review,” *International journal of engineering, Applied and Management Sciences*

Paradigms, vol. 14, Issue 01, 2014.

 ©The Authors. This work is licensed under the Creative Commons Attribution-NonCommercial-NoDerivatives 4.0 International License.