



# Concept Development and Design of Self-Transfer Devices for Wheelchair Users

**R. Hari Krishnan\* and S. Pugazhenth**

*School of Mechanical Engineering, SASTRA Deemed to be University, Thanjavur, Tamil Nadu-613 401, India*

(Received 7 October 2017; Accepted 30 November 2017; Published on line 1 March 2019)

\*Corresponding author: [harikrishnan.r@mech.sastra.edu](mailto:harikrishnan.r@mech.sastra.edu)

DOI: 10.5875/ausmt.v9i1.1621

**Abstract:** Movement disability not only affects mobility but also affects other daily activities of a person with disability which includes accessing toilet, moving to a chair, etc. A wide variety of mobility assistive devices are commercially available but, the devices that enable self-transfer of a wheelchair user from one surface to another, specifically addressing transfer to a toilet commode, is the need of the hour. In order to develop a manual and a powered self-transfer device, a methodical search of the entire solution space has been made by constructing a concept classification tree to decide on the choice of transfer posture, sequence of transfer motion, actuators, mechanisms and power source. Prior to this decision making, the procedure adopted for transferring a disabled person by a caregiver and the general techniques followed by the disabled people to transfer themselves in toilets are investigated. Later, after the conceptual design which is common to both manual and powered version is finalized, the design criteria and target specifications are put forward. Then, the self-transfer devices are developed that satisfy these design criteria and target specifications.

**Keywords:** Assistive Robotics; Self-Transfer; Transfer device; Wheelchair; Person with disability; Elderly

## Introduction

The independent living of a person with lower limb disability is often hindered when they have to depend on caregivers for transferring from one surface to another. This affects their self confidence and self esteem. For example, for a wheelchair user to use toilet, either he/she has to struggle himself/herself to transfer onto the toilet commode or fetch a caregiver's assistance to transfer, which will cause mental agony to the user [1], [2]. Wheelchair users have to go through the same psychological situation in public places where mostly wheelchairs are the only available assistive device and transferring to and from the wheelchair is a big question mark. Hence, an assistive device that will enable a wheelchair user to self-transfer from one surface to another will be of a great use. With such a device, the user can not only get transferred to a toilet commode, independently, but also to any other surfaces like his/her favourite chair, stool, etc. even in public places.

A few self-transfer aid devices have been

developed that addresses both mobility and self-transfer. Takahashi et al. had developed such a device that consists of a motor drive controlled tilt able arm carrying a saddle on top, hinged onto a mobile platform that employs omni-directional wheels [1], [3]. The user in the wheelchair approaches the device that has its saddle tilted downward and facing the user. He/she now places his/her chest onto the saddle and actuates the motor drive mechanism to tilt the arm upwards so as to bring the user in a standing and bending forward posture. In this posture, the user navigates to toilet and after reaching the commode, the mobile platform carrying the user turns until the user's bottom faces the toilet seat. Then the arm tilts downwards to place him/her onto the toilet seat.

Another device, Home, Lift, Position and Rehabilitation (HLPR) chair developed by National Institute of Standards and Technology, USA, addresses locomotion, lift assistance, rehabilitation and self-transfer [4]–[6]. The device consists of two inverted L-shaped frames, one inside the other, built on a fork lift like mechanism. The outer L-shaped frame is fixed to the

lift device and the inner L-shaped frame, which carries a seat, rotates within the outer L-frame. The user in HLPR chair, upon reaching the commode, is placed onto the toilet seat by first rotating the inner L-frame to orient him/her above the toilet seat, followed by lifting the user using a torso lift along with a comfortable sling that lifts the user from thighs. This allows the seat to be moved backwards so as to clear the area beneath the user and finally he/she can be lowered to be placed onto the toilet seat. TEK Robotic Mobilization Device (TEK RMD), developed by M/s. Matia Robotics, USA is another device that addresses self-transfer of a person with a lower limb disability [7], [8].

All the self-transfer devices discussed are alternative solutions that serve the purpose of mobility coupled with self-transfer. Among the three devices, only TEK RMD is commercially available and the other two devices are still prototypes in laboratories and have not become a product yet. TEK RMD is not affordable to PWD in developing countries because of their socio-economic conditions. Hence, instead of developing an alternative mobility solution, designing a self-transfer device as an attachment to a wheelchair will not only be a value addition to wheelchairs but also will result in a frugal solution. As there are broadly two categories of wheelchairs, manually propelled and powered, a focused research leading to product development of self-transfer attachment to both manual and powered wheelchairs is very much needed.

This paper addresses the conceptual design of the proposed self-transfer devices which involves decisions related to the transfer process, the intermediate stages and the mode of achieving the required motions. Before getting into the process of decision making, the procedure adopted for transferring a person by a caregiver and the general techniques followed by the disabled people to transfer themselves in toilets need to be studied. The target users of the device are wheelchair users with a lower limb disability due to chronic diseases

**R. Hari Krishnan** received his M.Sc. in Electronics from Mahatma Gandhi University, India and M. Tech. in Embedded Systems from Hindustan University, India in 2009 and 2010 respectively. He received Ph.D. from SASTRA Deemed to be University, India in 2017. He is currently Assistant Professor (Research) at School of Mechanical Engineering, SASTRA. His research interests include Assistive & rehabilitative robotics, Embedded Systems and Mechatronic systems. He is a member of IEEE, IEEE Robotics & Automation Society and Robotics Society of India (RSI).  
Email: [harikrishnan.r@mech.sastra.edu](mailto:harikrishnan.r@mech.sastra.edu)

**S. Pugazhenti** received his M. E. in Machine Tool Engineering from PSG College of Technology, Coimbatore, India and Ph.D. from IIT Madras, India in 1990 and 2004 respectively. He is currently Professor and Dean of the School of Mechanical Engineering, SASTRA Deemed to be University, India. He is a recipient of German Academic Exchange Service (DAAD) fellowship for the year 2002-2003 and was a guest researcher at the Mechatronics Centre, Leibniz University, Hannover, Germany. His research interests include mechatronics, parallel manipulators, mobile robots, assistive and rehabilitative robotics.  
Email: [pugazhenti@mech.sastra.edu](mailto:pugazhenti@mech.sastra.edu)

like polio, paraplegia, etc. or accidents.

## General procedure for toilet transfer

### *Transferring a person with lower limb disability by a caregiver*

In order to transfer a person from a bed or a chair to a wheelchair, first the caregiver stands facing the person to be transferred after applying the transfer belt around his/her waist. After making sure that the person's feet are flat on floor, the person is made to lean forward. The caregiver grasps the transfer belt at each side. If transfer belt is not being used, the caregiver passes his/her arms under the person's arms and rests them on their upper back as shown in Figure 1(a). Subsequently the caregiver assists the person to come to a standing position by gently pulling on the transfer belt or pulling the person upward and forward, if transfer belt is not used, as illustrated in Figure 1(b). Once the person is in standing position, the caregiver supports him/her by holding the transfer belt or by keeping their hands on his/her upper back. In this standing posture the person is made to turn by pivoting on the stronger leg until his/her bottom faces the seat of the wheelchair as shown in Figure 1 (c). Use of transfer turntable, designed to assist a caregiver to pivot a user while performing a standing transfer, is highly recommended to turn the person. Once the person's backside is positioned facing the wheelchair, he/she is lowered to place him/her onto the wheelchair seat [9].

The above mentioned transfer procedure involves high risk of injury to both the disabled person and the caregiver. Transferring disabled people manually from bed to wheelchair, wheelchair to toilet, etc. are identified to be high risk tasks and carrying out these tasks on daily basis increases the risks of spinal cord injuries to the caregivers [10].

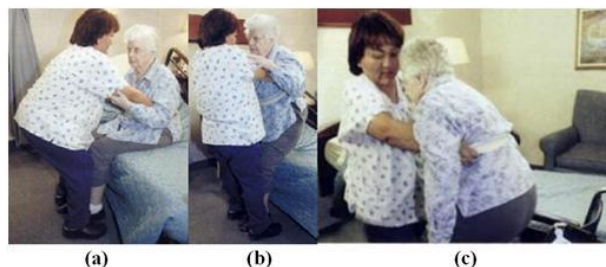

Figure 1. General procedure for transferring a person from bed to wheelchair [9].

### *Transferring without assistance*

Two techniques namely, diagonal approach and side approach are followed generally by a wheelchair user to transfer oneself from wheelchair to toilet seat and vice versa without any assistance from caregiver or using any major assistive devices [11]. Figure 2 illustrates

the steps involved in diagonal approach. The user positions the wheelchair diagonal to the toilet commode as shown in Figure 2(a), swings the foot rest out of the way and locks the break. Following which, he/she removes the armrest of the wheelchair that is adjacent to the commode, places one hand on the wheelchair seat and the other hand on the toilet seat as shown in Figure 2(b). Subsequently, the person can move across by redistributing weight on the hands. Once being transferred, as illustrated in Figure 2(c), the user grabs the handle fixed on the wall, if necessary while being seated at the edge of the toilet seat. At this position, he/she can move the wheelchair out of the way, if needed. Finally, the user positions himself/herself on the toilet seat as presented in Figure 2(d).

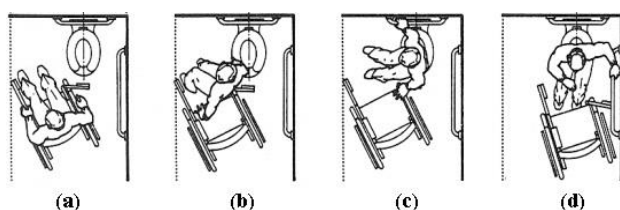

Figure 2. Diagonal approach for toilet transfer [11].

The steps involved in the side approach are illustrated in Figure 3. Unlike in diagonal approach, here the user positions the wheelchair parallel to the toilet commode as shown in Figure 3(a), removes the armrest and locks the breaks. Using the same weight transfer technique on the hands, the user transfers himself/herself to the toilet seat as depicted in Figure 3(b). As shown in Figure 3(c), he/she grabs the handle to adjust the seated position on the toilet seat.

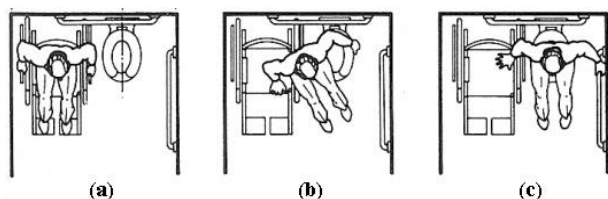

Figure 3. Side approach for toilet transfer [11].

Even though both these techniques are widely followed for the self-transfer, there is a high possibility of 'risk of fall' involved in it. The person has to transfer by redistributing weight on their hands and for this, he/she has to struggle to lift the body with arms and throw onto the toilet seat, which is difficult, unsafe and unhygienic.

### Concept development process

The concept development process for the design of self-transfer device involves a series of decisions such as starting & intermittent postures, types of motions involved and mechanisms to achieve this motion. To

make the decisions methodically by searching the entire solution space covering all options, a concept classification tree [12] is constructed as shown in Figure 4.

From the figure it can be seen that, the transfer motion can be achieved either in sitting posture or in standing posture. In sitting posture, transfer can happen by sliding the user himself/herself making use of a sliding board by exerting one's own physical strength or by making use of mechanisms to first vertically lift the user from top and then horizontally move him/her above the surface to be transferred, before being placed. For lifting the user who is being seated, either a chain pulley drive mechanism or a forklift like mechanism can be employed. Lift motion using pulley chain mechanism can be achieved using physical strength of the user where for example, he/she will be rotating a hand wheel to lift or lower. Alternatively, a motor can be employed to actuate the chain pulley drive. The actuators employed for forklift like lift mechanisms can be either linear actuators that require electrical power to operate, hydraulic cylinders that require a hydraulic power pack or pneumatic cylinders that make use of compressed air. As mentioned earlier, once the user has been vertically lifted he/she has to be moved horizontally above the surface to be transferred. To achieve this motion, the user can be slid horizontally over the surface, making use of hydraulic / pneumatic cylinders / linear actuators or could swing the user using a motor.

The transfer in standing posture involves two motions i.e. the user needs to be brought to a standing posture and then should be moved horizontally above the surface to be transferred. The lift could be achieved either from the top by making use of chain pulley drives/wires or from bottom employing hydraulic / pneumatic cylinders, linear actuators, hydraulic jack or gas springs. To move the user horizontally above the surface, he/she could either be slid towards the surface or can be swung in such a way that his/her bottom faces the surface to be transferred. To achieve sliding motion, hydraulic / pneumatic cylinders or linear actuators can be used and swing can be achieved by rotating a hand wheel by the user using his/her physical strength or by employing an electric motor.

From the various options available, the first and foremost decision is to choose between transfer motion in sitting posture and standing posture. If the user is transferred in sitting posture, he/she needs to be carried in a sling. Removing the sling before being seated onto the commode so as to expose the buttock of the user is another task. Hence transfer in standing posture is preferred. To transfer a wheelchair user in standing posture, first the user needs to be lifted to bring him/her

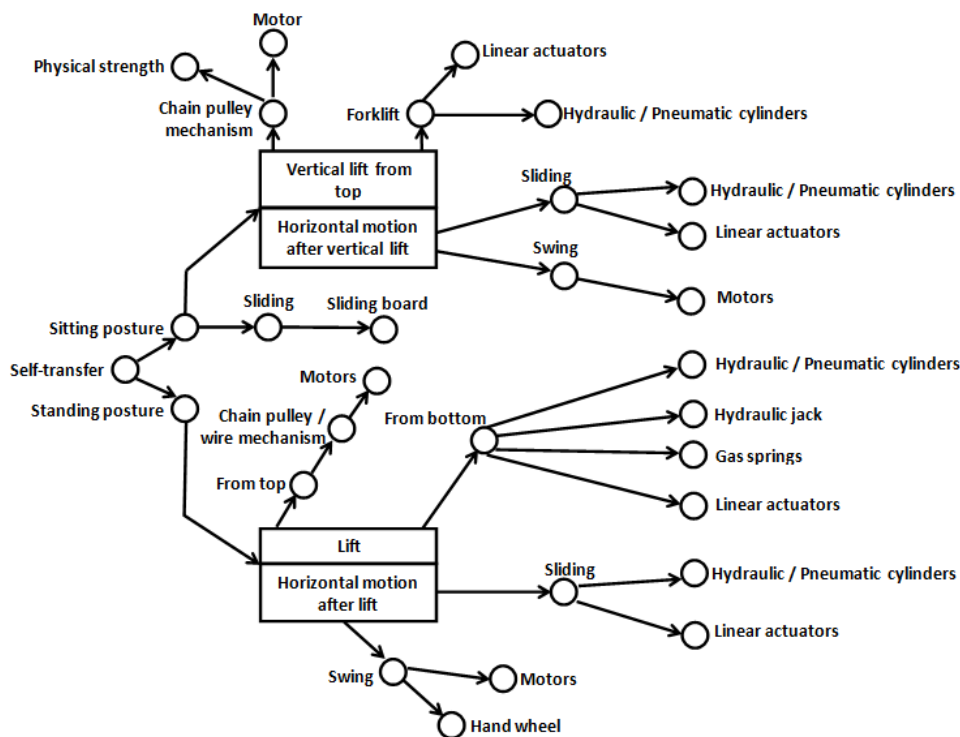

Figure 4. Concept classification tree with various options available.

to the standing posture and then moved horizontally towards the surface to be transferred. Lifting the user from the top is ruled out as it requires all the mechanisms to be at the top of the device, thus increasing the height of the system. Hence, lifting from the bottom is preferred. Hydraulic cylinders require hydraulic power pack which consumes more space & require frequent maintenance. Pneumatic cylinders require compressed air supply which is not possible to be provided everywhere. Hydraulic jacks are too heavy to be used along with the wheelchair & they suffer from the disadvantage of minimal stroke length. Hence, gas springs are selected for manual version and linear actuators are selected for the powered version. For horizontal movement after the lift, swing motion is preferred to sliding motion, as the size of the device may increase while the user is being slid and moreover the wheelchair needs to be aligned in parallel to the commode, which is difficult in most of the bathroom conditions. Horizontal rotation by means of hand wheel is chosen for manual version of the self-transfer device and motor actuated rotation is chosen for the powered version. The selected options so as to achieve the required transfer motions are highlighted in the concept classification tree as depicted in Figure 5. The entities common for both manual and powered versions are shown in green. Entities in red belong to the manual version while the entities in blue are the options chosen for the powered version.

The power required for the operation of the powered version can either be drawn from an independent power source or can make use of the power from the wheelchair battery. If an independent power source is used, the batteries will consume space, making the system bulky. Moreover, the user has to charge the battery in the device and the wheelchair battery separately, which is practically difficult for him/her. Hence, it is decided to use the wheelchair battery for the operation of the transfer device.

The chosen transfer motion highlighted in Figure 5 closely resembles the general procedure of transferring a disabled person by a caregiver and overcomes the limitations of toilet transferring process mentioned in previous sections.

### Conceptual design of proposed self-transfer devices

The conceptual design based on the selected options of concepts discussed in the previous section is presented in Figure 6. The transfer device is shown attached to a wheelchair in the figure. The device consists of a length-adjustable arm, hinged to the centre of a turntable, with a cushioned saddle on top. The length as well as the angle of tilt of the arm can be altered through actuation of gas springs or linear actuators. The saddle has two short support poles on either side.

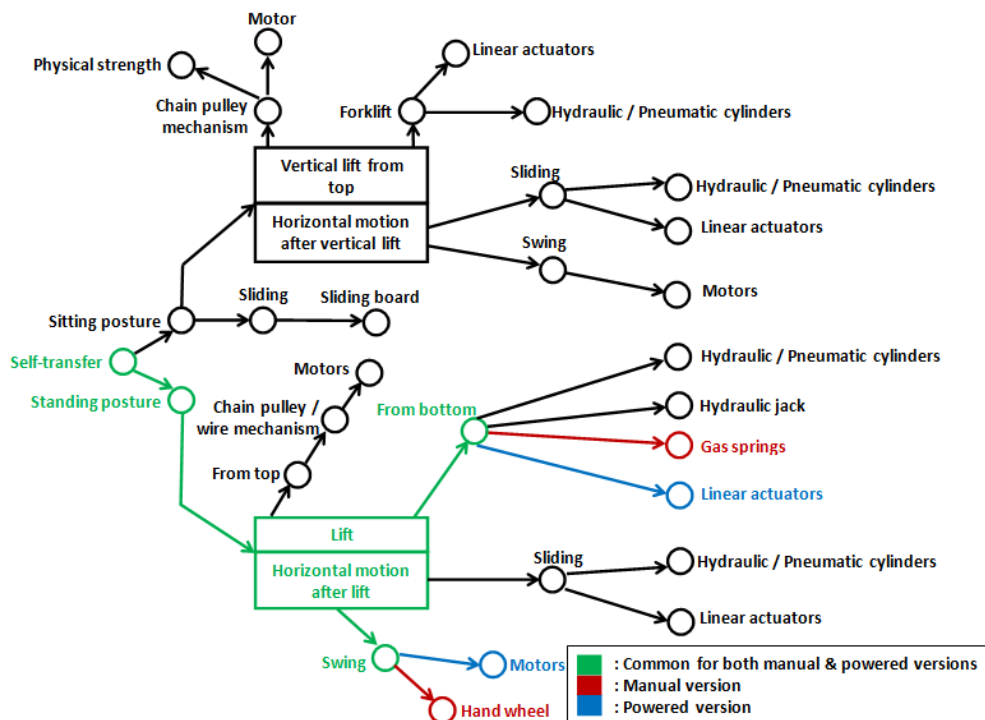

Figure 5. Concept classification tree highlighting the chosen options.

The user can approach commode in a toilet by sitting in a wheelchair with the self-transfer device attached to it. Once in front of the commode in stage 1 of the transfer motion, the user leans forward and rests his/her chest onto the cushioned saddle. The two support poles on either side of the saddle pass under the person's arms, similar to the action of caregiver's arm passing under the patient's arm, to hold him/her as in general procedure of transfer as illustrated in Figure 1(a). In stage 2, the user raises himself/herself by actuating the arm to tilt and elongate simultaneously, in the same manner the caregiver gently pulling the person frontward and upward as shown in Figure 1(b). At stage 3, arm becomes vertical, and brings the user in a standing and bending forward posture. During stage 4, the user rotates the turntable until the user's bottom is positioned above the toilet seat. The rotation can be achieved by a hand wheel in the case of manual self-transfer device and by means of a motor in the powered version of the device. At the end of this stage, the user can pull down clothes. In stage 5, the arm is shortened and tilted in the opposite direction to that of the raise motion placing the user onto the toilet seat. Transferring back to the wheelchair could be achieved by following the same procedure in the reverse order [13]. The design is in such a way that, the device can be easily attached or detached whenever necessary so that during normal locomotion, the transfer device need not be carried along with the wheelchair.

Even though, in the conceptual design, transferring from a wheelchair to a toilet commode is discussed, the

system is designed to transfer a user to any other surface like another chair, two wheeler seat, a stool, etc.

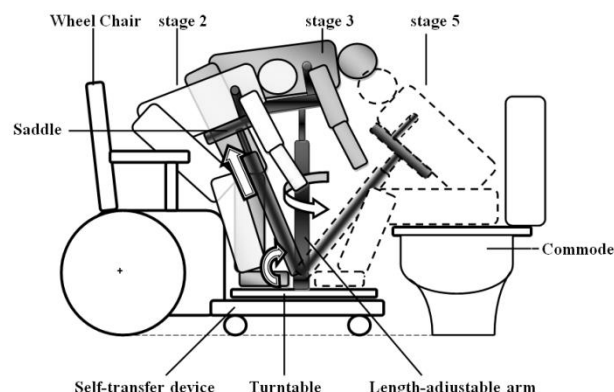

Figure 6. Conceptual design of self-transfer device showing stages of transfer motion [18].

### Design Criteria and Target Specifications

The self-transfer device under consideration is meant to be used in an interior environment having a smooth and flat terrain. The device needs to be designed in such a way that, when attached to a wheelchair, it should be accommodated inside a standard bathroom. The wheelchair friendly bathrooms in public places have a standard dimension of 2.415 m (L) x 1.525 m (W), [14] specifically designed to accommodate standard manual wheelchairs that measure 1.10 m to 1.25 m [15]. Hence the length of the system, when the transfer device is attached to a wheelchair, should not exceed a limit of 1.50 m. Similarly, the width of the device should be

Table 1. Target specifications.

<i>Parameters/features</i>	<i>Specifications</i>
Length while attached to a wheelchair	< 1.50 m
Floor to turntable height	0.15 m to 0.20 m
Turntable diameter	0.45 m to 0.55 m
Transfer surface height	0.40 m to 0.77 m
Device mass (without wheelchair)	upto 50 kg
Pay load	Manual: 50 kg to 75 kg Powered: 100 kg
Torque to rotate the turntable	< 30 Nm
Transfer time	< 60 s
Wheelchair-Transfer device attachment/ detachment time	< 30 s
Bathroom size	< 2.415 m long x 1.525 m wide

within the outer width of the wheelchair, measured between the hand rims attached to the rear wheels which ranges from 0.60 m to 0.70 m [15].

The turntable should be kept more or less at the same level of the footrest of the wheelchair. The footrest of a standard wheelchair is at a height ranging from 0.18 m to 0.22 m [15]. Hence the floor to turntable height should be more or less between 0.15 m and 0.20 m and yet, the space below the turntable should be enough to accommodate the castor wheels, base frame and the gears. The diameter of the turntable is another important criterion to be considered. The turntable should have enough space to accommodate the limbs of a person having flexion contracture at knee. The distance between the frames which hold the footrests in front of a standard wheelchair measures between 0.45 m to 0.55 m and hence, the turntable diameter should be within this range, depending on the wheelchair used.

The transfer device is to be designed for transferring to different surfaces. The device should be able to transfer the user to a commode which has a height of 0.4 m or to a scooter seat at a height of 0.77 m.

The weight of the device is another important design criterion. The device should not be heavy for the user, as he/she has to propel the wheelchair along with the transfer device using the hand rims and at the same time the device should be sturdy enough to avoid instability during transfer. As the rolling friction coefficient of the wheel on a smooth & flat floor is around 0.005, the user can propel the wheelchair with minimal effort. Moreover, when the transfer device is attached to the wheelchair, the weight of the transfer device does not act on the wheelchair as the transfer

device will be rolling on castor wheels along with the wheelchair. Thus weight of the transfer device will not be a burden for the user. Hence, sturdiness of the device should be given preference over light weight.

While using the manual version, the user needs to rotate the platform on which he/she is standing using a hand wheel. Thus one of the major design considerations is that, the user should be able to rotate the platform with ease. Studies have reported that the human hands are capable of achieving a torque of 55 Nm to rotate a horizontally placed hand wheel [16] and manual wheelchairs are designed for a maximum torque of 30 Nm to propel by hands [17]. Hence, the torque required to rotate the platform should be within these values.

The time required to attach/detach the transfer device to/from the wheelchair and the duration to achieve transfer should be as minimum as possible, only then the users will be encouraged to use the device. Users should be able to attach or detach the transfer device in less than 30 seconds and the duration of the transfer motion should not exceed more than a minute. The target specifications for the various features/parameters based on the design criteria are compiled and furnished in Table 1.

## Development of self-transfer devices

Based on the options selected, after decision making, a manual and a powered self-transfer device have been developed. The details of the developed devices are discussed in the following sub-sections.

### Manual Self-Transfer Device

A computer aided design (CAD) model of the manual self-transfer device, as shown in Figure 7, has been created. As mentioned in the previous sections, first the user needs to be raised to standing posture, then rotated and finally lowered so as to achieve self-transfer and hence the manual self-transfer device consists of two modules namely raise/sit assistance module and turn module.

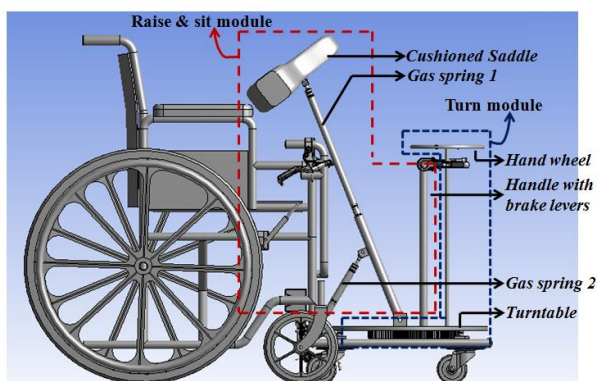

Figure 7. CAD model of manual self-transfer device attached to a wheelchair [18].

As per the actuator selected using concept classification tree, gas springs are employed to achieve raise/sit motion in manual self-transfer device and hence two gas springs, 1 and 2 are connected in the configuration as shown in Figure 7. While gas spring 1 enables height adjustment, gas spring 2 facilitates upward and downward tilt of the length-adjustable arm which constitutes gas spring 1 and the saddle. Lockable gas springs are used as it enables the rod to be locked at any point along its stroke length by pressing or releasing its 'release pin' using brake lever connected via Bowden cable.

The extension force of the gas springs should be adequate to carry the user's upper body, so as to achieve 'raise' motion and at the same time should be optimal enough for the user to compress the rod back into the cylinder with ease during 'sit' motion. Hence, gas spring 1 of standard force capacity of 250 N and gas spring 2 of 400 N have been chosen based on the estimation of extension and compression forces of the gas springs [18].

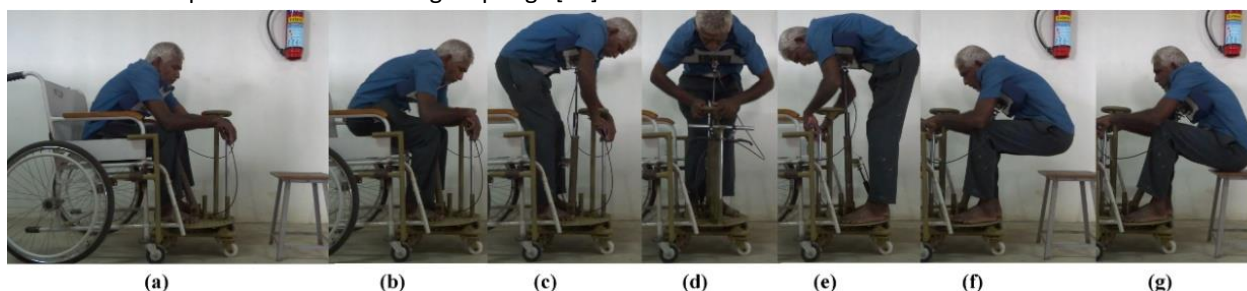

Figure 9. Process of transfer of a person from wheelchair to a stool using manual self-transfer device [18].

The turn assistance module consists of a turntable that can be rotated manually by a hand wheel. The turntable has an epicyclic gear arrangement underneath it with a sun gear attached to the frame and revolving planetary gear attached to the shaft connected to the hand wheel [18]. The torque required to rotate the turntable has been determined to be 12 Nm after estimating mass moment of inertia (MOI) of a human body in bending forward posture [19]. The manual transfer device has a payload capacity of 50 kg to 75 kg. The developed manual self-transfer device attached to a manual wheelchair is shown in Figure 8.



Figure 8. Side view (a) and front view (b) of the manual self-transfer device [18].

In order to achieve transfer from wheelchair to another chair, the user first leans forward to place his/her chest onto the saddle. The saddle is padded with orthopedic foam to ensure cushioning and is covered with a 'soft touch' fabric. A side support in the form of a short pole wrapped with foam is provided on either side of the saddle and it goes below the under arms when the user places his/her chest on top of the saddle. The user subsequently actuates gas spring 2 to come to a standing and bending forward posture. Gas spring 1 can be actuated if height adjustment is required. Once the user is in a comfortable height, he/she turns the hand wheel in front of him/her to rotate the turntable on which he/she is standing until his/her bottom faces the chair. Later, gas spring 1 is actuated by simultaneously applying a counter force by pressing the chest against the saddle for reducing the height. Following which, gas spring 2 is actuated and due to the load on top of the saddle, it is

Table 2. Specifications of manual self-transfer device.

Parameters/features	Specifications
Size (along with wheelchair)	1.16 m long x 0.77 m wide x 0.9 m high
Ground clearance	0.09 m
Floor to turntable height	0.175 m
Turntable diameter	0.45 m
Height of the length-adjustable arm from turntable top to saddle top	Minimum: 0.72 m, Maximum: 0.9 m
Transfer surface height	From 0.40 m to 0.77 m
Device mass (without wheelchair)	30 kg
Payload	50 kg to 75 kg
Actuators	
<ul style="list-style-type: none"> <li>Gas spring 1</li> </ul>	Load: 250 N, Stroke length: 250 mm
<ul style="list-style-type: none"> <li>Gas spring 2</li> </ul>	Load: 400 N, Stroke length: 75 mm
Wheelchair-Transfer device attachment /detachment time	< 15 s
Transfer time	< 45 s
Minimum bathroom size	1.7 m long x 0.9 m wide

compressed to seat the person onto the chair. The entire process of transfer from wheelchair to another surface is depicted in Figure 9 [18].

The complete design specifications of the manual self-transfer device are provided in Table 2. A little consideration will show that, the specifications such as length of the system when attached to a wheelchair, floor to turntable height, transfer surface height, mass of the device and attachment & transfer time are well within the target specifications provided in Table 1.

In order to ensure stability and reliability of the device developed, static force analysis is done by considering the most critical condition, when the user is being placed onto the commode, diametrically opposite to the wheelchair as shown in Figure 10. The disturbing moment due to the weight of the person may tend to topple the device about the front wheels of the transfer device and hence, the centre point of the front wheel is taken as the pivot point for moment calculations.

The total weight of the user, 726 N (74 kg) is assumed to be acting at the COG (G) which is found to be 250 mm away from the pivot point. A load of 294 N (30 kg) each acts at the centre of gravity of the wheelchair and the transfer device at a distance of approximately 670 mm and 140 mm respectively from the pivot point. A disturbing moment of 182 Nm ( $726 \text{ N} \times 0.25 \text{ m}$ ) is countered by a restoring moment of 238 Nm  $\{(294 \text{ N} \times$

$0.67 \text{ m}) + (294 \text{ N} \times 0.14 \text{ m})\}$  making the device stable. This result is applicable for the powered self-transfer device also and in fact the restoring moment will be slightly high in this case as the mass of the powered wheelchair will be considerably more than manual wheelchair due to the presence of batteries. This is later affirmed during the trials with the potential beneficiaries as the devices did not experience any instability or tendency to topple throughout the trials.

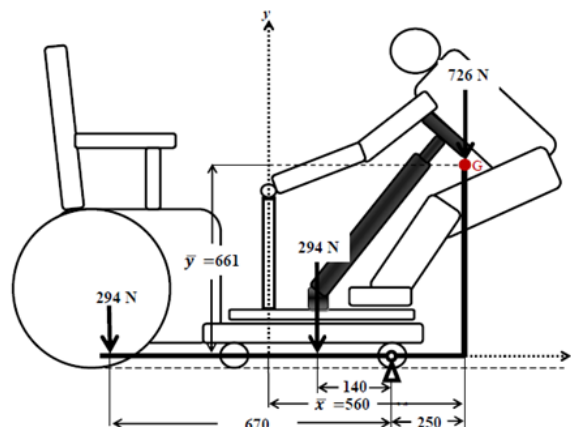

Figure 10. Force diagram for instantaneous moment estimation (All dimensions are in mm).

### Powered Self-Transfer Device

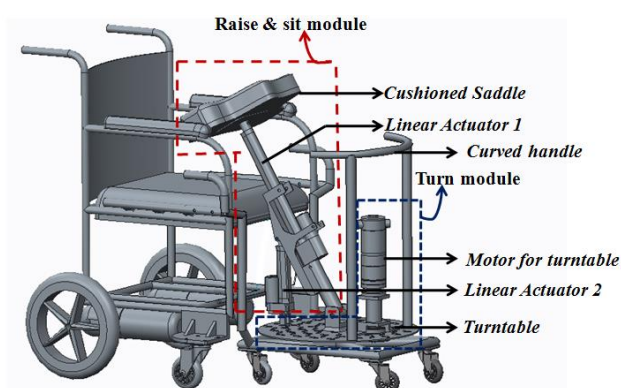

Figure 11. CAD model of the powered self-transfer device attached to a powered wheelchair [20].

Based on the options selected for powered self-transfer device using concept classification tree and conceptual design discussed, a CAD model of the powered self-transfer device has been created as shown in Figure 11.



Figure 12. Side view (a) and front view (b) of the powered self-transfer device [20].

Similar to the manual self-transfer device, the powered self-transfer device also consists of two modules namely, raise/ sit assistance module and turn assistance module. Unlike the manual device, in raise/sit assistance module, instead of gas springs, linear actuators are employed to assist a person raise or sit on to a surface. Linear actuator 1 with a standard load capacity of 1000N and stroke length of 300 mm and linear actuator 2 with a load capacity of 1000N with a stroke length of 100 mm are being used [20]. In turn assistance module, instead of hand wheel mechanism to

physically provide the force to rotate the turntable, a motor with a torque capacity of 15 Nm and a speed of 11rpm is employed. The powered transfer device has a payload capacity of up to 100 kg [20]. The developed powered self-transfer device attached to a powered wheelchair is shown in Figure 12.

Three thumb joysticks, 'A', 'B' and 'C' are employed for tilt, height and turn control respectively. The user after placing his/her chest on to the saddle, can reach forward to hold the handle and 'push up' the joystick 'A' to simultaneously actuate linear actuator 1 and 2 so as to bring him/her to a standing and bending forward posture. He/she needs to 'push up' the joystick 'B', if further height adjustment is required. The person can now operate joystick 'C' to turn the turntable. Once the person's bottom is positioned above the surface to which transfer is needed, joystick 'B' needs to be 'pushed down' if height reduction is required. Then joystick 'A' is 'pushed down' to simultaneously actuate both the linear actuators to seat the person onto the surface. The entire process of transfer from wheel chair to another surface is depicted in Figure 13[20]. The specifications of the powered self-transfer device are provided in Table 3.

### Conclusion

The conceptual design of the self-transfer devices has been finalized through a systematic concept development process by constructing a concept classification tree. Prior to constructing the tree and selecting appropriate branches, general procedure adopted for transferring a wheelchair user by a caregiver as well as techniques used by wheelchair users to transfer themselves onto toilet commodes have been studied. Target specifications of the transfer devices have been finalized based on the design criteria such as standard dimensions of wheelchairs and bathrooms as well as the convenience of target users. Based on the conceptual design, a manual and a powered self-transfer device have been developed that can be used as an attachment to a manual and powered wheelchair respectively. The devices are not only first of its kind but also frugal. When produced on a large scale, the manual

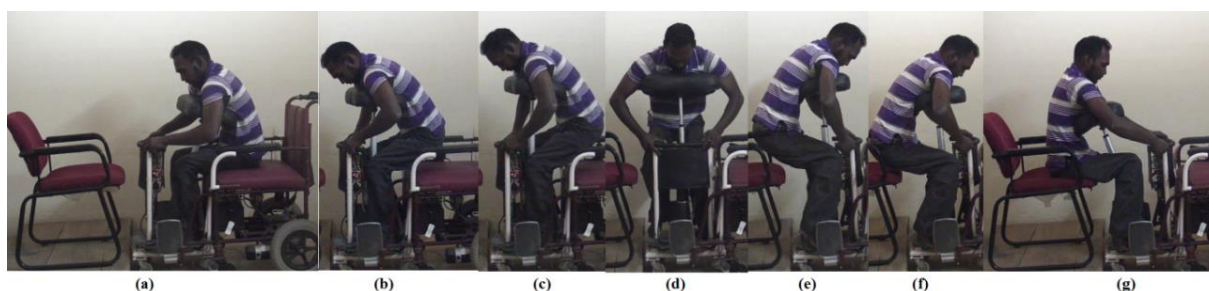

Figure 13. Process of transfer of a person from wheelchair to a chair using powered self-transfer device [20].

Table 3. Specifications of the Powered Self-Transfer Device.

<b>Parameters/features</b>	<b>Specifications</b>
Size (along with Wheelchair)	1.07 m long x 0.6 m wide x 0.9 m high
Ground clearance	0.095 m
Floor to turntable height	0.175 m
Turntable diameter	0.45 m
Height of the length-adjustable arm from turntable top to saddle top	Minimum: 0.76 m, Maximum: 0.9 m
Transfer surface height	From 0.40 m to 0.77 m
Device mass (without wheelchair)	30 kg
Payload	Up to 100 kg
Motors	
1. Linear actuator 1	Load: 1000 N, Stroke length: 300 mm, Speed: 10 mm/s
2. Linear actuator 2	Load: 1000 N, Stroke length: 100 mm, Speed: 10 mm/s
3. Turntable motor	Torque 15 Nm, Speed: 11 rpm
Power source	(2 x 12v), 18 Ah Batteries in the wheelchair
Control Unit	PIC 16F877A microcontroller development board
Wheelchair-Transfer device attachment /detachment time	< 15 s
Transfer time	< 60 s
Minimum bathroom size	1.7 m long x 0.9 m wide

and the powered self-transfer devices can be made available at a cost of less than 40% of manual and powered wheelchairs respectively.

## Acknowledgment

The authors are grateful to Science and Engineering Research Board (SERB), Department of Science and Technology (DST), Government of India, for the financial support (SB/S3/MMER/0068/2013) to the project titled "Design and development of a wheelchair-based assistive robotic system with self-transfer facility."

## References

- [1] Y. Takahashi, G. Manabe, K. Takahashi, and T. Hatakeyama, "Simple self-transfer aid robotic system," in proceeding of *2003 IEEE International Conference on Robotics and Automation*, 2003, vol. 2, no. 2, pp. 2305–2310. doi:[10.1109/ROBOT.2003.1241937](https://doi.org/10.1109/ROBOT.2003.1241937)
- [2] R. H. Krishnan and S. Pugazhenthii, "Mobility assistive devices and self-transfer robotic systems for elderly, a review," *Intelligent Service Robotics*. 2014. doi:[10.1007/s11370-013-0142-6](https://doi.org/10.1007/s11370-013-0142-6)
- [3] Y. Takahashi and T. Yamaguchi, "Psychological evaluation of simple self-transfer aid robotic system with horizontal movement system," *IEEE Int. Symp. Ind. Electron.*, pp. 1925–1930, 2010. doi:[10.1109/ISIE.2010.5637525](https://doi.org/10.1109/ISIE.2010.5637525)
- [4] R. Bostelman and J. Albus, "Robotic Patient Transfer and Rehabilitation Device for Patient Care Facilities or the Home," *Adv. Robot.*, vol. 22, no. 12, pp. 1287–1307, 2008. doi:[10.1163/156855308X344837](https://doi.org/10.1163/156855308X344837)
- [5] R. Bostelman and J. Albus, "A multipurpose robotic wheelchair and rehabilitation device for the home," in proceeding of *IEEE/RSJ International Conference on Intelligent Robots and Systems*, USA, Oct. 29 - Nov. 2, 2007, pp. 3348–3353. doi:[10.1109/IROS.2007.4398980](https://doi.org/10.1109/IROS.2007.4398980)
- [6] R. Bostelman and J. Albus, "Robotic Patient Lift and Transfer," in *Service Robot Applications*, Intechopen, 2008, pp. 1–21. doi:[doi.org/10.5772/6069](https://doi.org/10.5772/6069)
- [7] N. Hacikadiroglu and E. Canidemier, "Mobility

- device for physically disabled people,” US Patent: 20150190293, 2015.
- [8] “Can I use it? - TEK Robotic Mobility Device.” [Online]. Available: <http://www.tek-rmd.co.uk/can-i-use-it/>. [Accessed: 02 January 2017]
- [9] P. J. Carter, *Lippincott’s textbook for nursing assistants: a humanistic approach to caregiving*. Wolters Kluwer Health/Lippincott Williams & Wilkins, 2008.
- [10] A. L. Nelson, “Variations in High-Risk Patient Handling Tasks by Practice Setting,” in *Safe Patient Handling and Movement: A Practical Guide for Health Care Professionals*, New York: Springer, 2006, pp. 47–57.
- [11] “Wheelchair Bathroom Transfer Techniques.” [Online]. Available: <http://www.handicappedequipment.org/wheelchair-bathroom-transfer-techniques/>. [Accessed: 02 January 2017]
- [12] K. T. Ulrich and S. D. Eppinger, *Product design and development*. McGraw-Hill/Irwin, 2012.
- [13] R. Hari Krishnan and S. Pugazhenthhi, “Development of a self-transfer robotic facility for elderly and disabled,” in proceeding of *International Conference on Robotics, Automation, Control and Embedded Systems (RACE)*, India, Feb. 18-20, 2015, pp. 1–4. doi: [10.1109/RACE.2015.7097246](https://doi.org/10.1109/RACE.2015.7097246)
- [14] *Accessible and Usable Buildings and Facilities (ICC A17.1-2009)*. Washington DC: International Code Council (ICC), 2011.
- [15] United Nations Enable, “Accessibility for the disabled-A Design Manual for a Barrier free Environment,” 2004. [Online]. Available: <http://www.un.org/esa/socdev/enable/designm/AD5-02.htm>. [Accessed: 12 February 2017]
- [16] H. J. Bullinge and M. Braun, “Handwheels,” in *International Encyclopedia of Ergonomics and Human Factors*, Second., FL: CRC Press, 2006, pp. 1414–1418.
- [17] A. Koontz, R. Cooper, M. Boninger, Y. Yang, B. Impink, and L. Van Der Woude, “A kinetic analysis of manual wheelchair propulsion during start-up on select indoor and outdoor surfaces,” *J. Rehabil. Res. Dev.*, vol. 42, no. 4, pp. 447–458, 2005. doi: [10.1682/JRRD.2004.08.0106](https://doi.org/10.1682/JRRD.2004.08.0106)
- [18] R. Hari Krishnan and S. Pugazhenthhi, “Design and Development of a Wheel Chair Based Manual Self-Transfer Device for Elderly and Disabled,” *J. Med. Device.*, vol. 10, no. 2, p. 24501, 2016. doi: [10.1115/1.4032867](https://doi.org/10.1115/1.4032867)
- [19] R. Hari Krishnan, V. Devanandh, A. K. Brahma, and S. Pugazhenthhi, “Estimation of mass moment of inertia of human body, when bending forward, for the design of a self-transfer robotic facility,” *J. Eng. Sci. Technol.*, vol. 11, no. 2, pp. 166–176, 2016.
- [20] R. Hari Krishnan and S. Pugazhenthhi, “Design and development of a robotic self-transfer device for wheelchair users,” *J. Enabling Technol.*, vol. 11, no. 2, pp. 59–72, 2017. doi: [10.1108/JET-12-2016-0025](https://doi.org/10.1108/JET-12-2016-0025)

 ©The Authors. This work is licensed under the Creative Commons Attribution-NonCommercial-NoDerivatives 4.0 International License.